

NRAES

# ORCHARD SPRAYING: GETTING RESULTS

— A Guide to Orchard Sprayer Calibration —

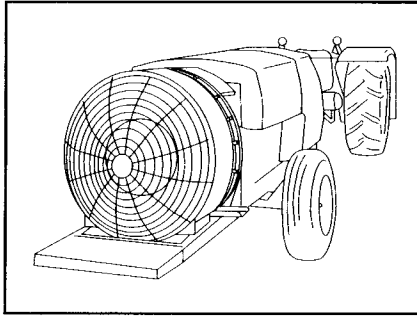

Typical air-blast sprayer.

Understanding sprayer performance could mean the difference between adequate pest control and disease management—and disaster. Accurate pesticide application depends on the proper maintenance and calibration of your sprayer.

USDA and EPA guidelines state that growers should apply pesticides within 5% of the labeled rate, but studies conducted by the Cornell Cooperative Extension System showed that many growers applied either more or less material than intended. That cost them control and money.

Many of the newer pesticides are applied at rates of ounces per acre, which makes accurate spraying even more important. For optimum performance, check your sprayer's operation before each application season and preferably during the season as well.

Here are some ways to ensure your sprayer is calibrated and operating properly.

## Precalibration Check

Before calibrating, check the sprayer.

### STEP 1

Pull out the filter or strainer and clean it if necessary (figure 1). A dirty strainer can restrict the flow and reduce spraying pressure of the pesticide solution.

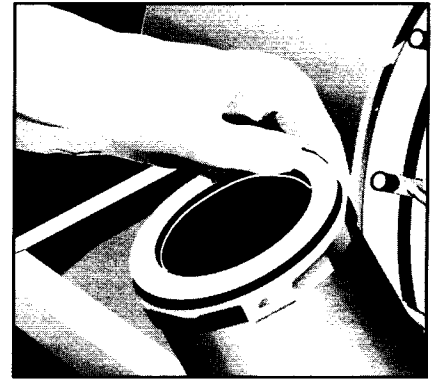

Figure 1. Filter check.

### STEP 2

Check the nozzles on the nozzle manifold. Remove each of the nozzles and clean them, removing any obstructions with an old toothbrush or other soft brush (figure 2).

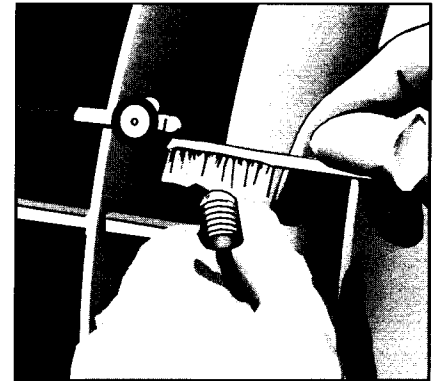

Figure 2. Nozzle cleaning.

### STEP 3

Inspect the fan to see that the blades are not damaged. Check for dirt or other obstacles that may reduce airflow (figure 3).

### STEP 4

With the fan on and the spray off, check the airflow around the fan outlet by moving your hand around the nozzles. Adequate airflow around all the nozzles is necessary to deliver the spray to all parts of the trees.

### STEP 5

Check for leaks by running the sprayer with clean water. If there are leaks, repair them before filling with pesticide solution.

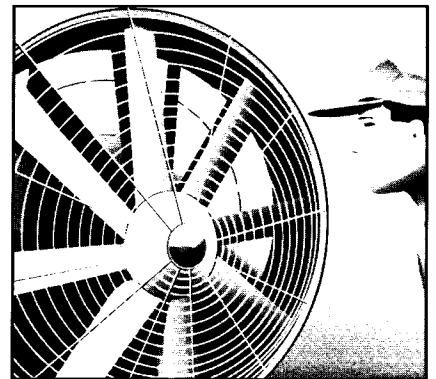

Figure 3. Fan check.

## Field Calibration

After the precalibration check, it is time to calibrate your sprayer. Throughout calibration, remember to use only clean water in the tank for safety. Use personal protective clothing, such as a spray suit, gloves, boots, and goggles.

A common way to calibrate is to spray a known area, then check the tank to determine the amount of water used. To calibrate by area, select an area larger than 1 row, but smaller than 5 acres. Know the exact size of the check area sprayed for accurate results.

Set up a permanent calibration course with trees as markers. Calculate the area of the course using the following formula:

$$\text{Calibration course area (acres)} = \frac{\left(\frac{\text{distance between rows}}{43,560 \text{ ft}^2/\text{acre}}\right) \times \left(\frac{\text{distance between trees}}{43,560 \text{ ft}^2/\text{acre}}\right) \times \left(\frac{\text{number of trees per row}}{43,560 \text{ ft}^2/\text{acre}}\right)}{43,560 \text{ ft}^2/\text{acre}}$$

(distance is measured in feet)

Determine gallons of spray needed per acre. The intended application rate is determined by following label instructions and the size and shape of the tree. Spray within the test area and accurately measure the amount of water used. If the actual amount of water used equals the needed amount, your sprayer is calibrated correctly. This technique is a good way to quickly check sprayer operation, but it does not help identify which operating parameters are out of adjustment. A more accurate calibration method involves checking all factors that influence application accuracy.

## Travel Speed

Travel speed influences the accuracy of the application as well as the spray distribution in the trees. If

you travel too fast while spraying, you may not put enough material on the trees and the spray pattern may be distorted. If you travel too slowly, you may be applying too much spray. Both negatively affect coverage and performance. Travel speed is influenced by a number of factors—operating gear, engine speed, tire slippage, ground conditions, and the power requirements of the sprayer.

One way to check travel speed is to drive the tractor and sprayer over a test course in an orchard. Know the travel speed to the nearest tenth of a mile (figure 4).

- Measure a test course of 100–200 feet. The longer the course, the more accurate the speed calculated. Mark the beginning and the end of the course with temporary markers, such as flags, or more permanent markers, such as trees.
- Fill the sprayer tank with water, 1/3 to 2/3 full, to simulate average field conditions.
- With the sprayer operating at field pressure, travel at your spraying speed before you reach the beginning marker. This means that you will travel at a consistent speed throughout the course.
- Have a second person walk alongside the tractor and sprayer with a stopwatch to note the time elapsed between the beginning and the end of the course.

- Repeat the test and average the results of the two runs.
- Use the following formula to determine travel speed:

$$\text{Speed (MPH)} = \frac{(\text{distance in feet}) \times (60)}{(\text{time in seconds}) \times (88)}$$

MPH = miles per hour

60 and 80 = constants to make units consistent

- If the measured travel speed is different from the intended speed, change the gear or throttle settings to achieve the desired speed. Do not adjust the throttle speed so that it reduces spray pressure or fan speed.

## Pressure Check

The pressure of the spray solution at the nozzles is a key to applying the correct amount of material to the tree. Pressure affects droplet size, which influences coverage and drift. The pressure that counts is at the nozzle where the spray solution is converted into droplets, not at the pump.

To check nozzle pressure, use an accurate pressure gauge (figure 5). Liquid-filled gauges are recommended. Place the pressure gauge on the nozzle fitting farthest from the pump and turn the sprayer on. If the pressure is lower at the nozzle than specified, you may need to increase pressure at the regulator to obtain the required pressure at the nozzle.

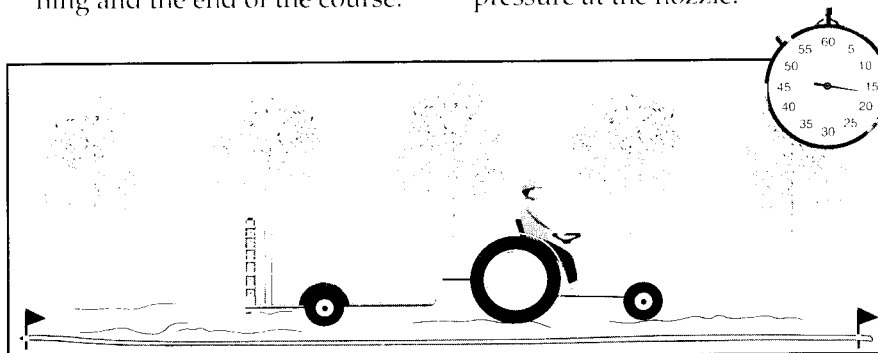

Figure 4. Estimating travel speed.

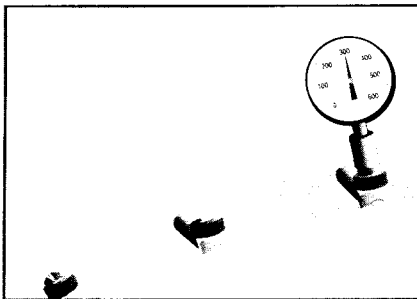

Figure 5. Checking nozzle pressure with a pressure gauge.

## Nozzle Output

A nozzle is designed to deliver a specific number of gallons per minute when operating at a specific pressure. It is important to select the type of nozzle you need for each particular application based on the nozzle flow rate, spray pattern, and spray coverage required.

Obtaining the desired flow rate from nozzles is fundamental to accurate spray application. Worn nozzles can apply more spray material than is needed, which means overapplication and wasted money. A nozzle obstruction can reduce or stop delivery—parts of the orchard will not receive enough spray.

You can check actual nozzle output by using a flow meter (figure 6). A flow meter fits over the nozzle opening and, when the sprayer is running, will show the flow rate through the nozzle in gallons per minute (GPM).

Another way to check flow rate is to connect hoses to each of the nozzles, turn on the sprayer, and direct the hose flow into pails or barrels (figure 7). Measure the gallons of water from each nozzle or an entire side of the sprayer over a brief period. Divide the number of gallons collected by the total collection time to determine the flow rate through the nozzle in

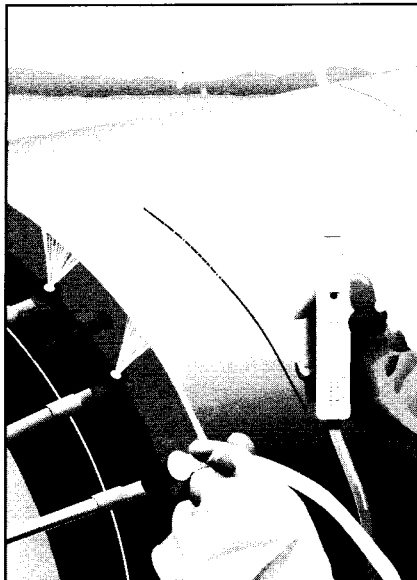

Figure 6. Using a flow meter to measure nozzle flow rate.

gallons per minute. It is important to make all measurements as accurately as possible.

If the nozzle flow rate is more than 10% different from the desired flow rate for the measured nozzle pressure, replace the nozzle.

This technique also works well on sprayers that use air-shear nozzles. The hoses that deliver spray solution to the nozzles can be directed into collection containers to measure sprayer output.



Figure 7. Measuring nozzle flow rate.

## Calculating Application Rate

If you know the total nozzle output, travel speed, and row spacing, use the following formula to calculate the application rate or gallons per acre sprayed:

$$\text{Gallons per acre} = \frac{\left( \text{nozzle output in GPM} \right) \times \left( 495 \right)}{\left( \text{travel speed in MPH} \right) \times \left( \text{space between rows in feet} \right)}$$

*GPM = gallons per minute*

*MPH = miles per hour*

*495 = constant to make units consistent*

## Correcting Sprayer Output

The following equations can be used to determine adjustments to sprayer operation that will provide the required output:

$$\text{MPH needed} = \left( \text{MPH measured} \right) \times \left( \frac{\text{GPA measured}}{\text{GPA needed}} \right)$$

$$\text{PSI needed} = \left( \text{PSI measured} \right) \times \left( \frac{\text{GPA needed}}{\text{GPA measured}} \right)^2$$

*MPH = miles per hour*

*GPA = gallons per acre*

*PSI = pounds per square inch*

Use a different type of nozzle if you need to make great changes to sprayer output. Consult nozzle manufacturers or their catalogs to see how pressure changes affect droplet size.

Another method of adjusting the application rate is changing the pesticide-to-water mix. Always stay with recommended label rates.

## Field Checks

While spraying in the orchard, check the sprayer to see that the nozzles are operating properly. From the tractor seat, you can see if a nozzle is blocked or if the spray patterns are distorted. Be sure that the spray is reaching all areas of the tree. If it is not, adjust the fan speed or air deflectors to improve spray coverage.

To check the angle of the air discharge, attach a length of ribbon or other streamer to the top and bottom air deflectors on both sides of the sprayer and at the top and bottom of the tree foliage. Operate the sprayer fan and adjust the air deflectors on the sprayer until the ribbons on the sprayer and the tree are aligned (figure 8).

To check spray coverage, staple water-sensitive paper along a test row and spray the row with water. Changes in the color of the paper indicate whether the spray reached that area of the tree. The spots of changed color on the paper are a good indication of droplet size and the amount of spray coverage.

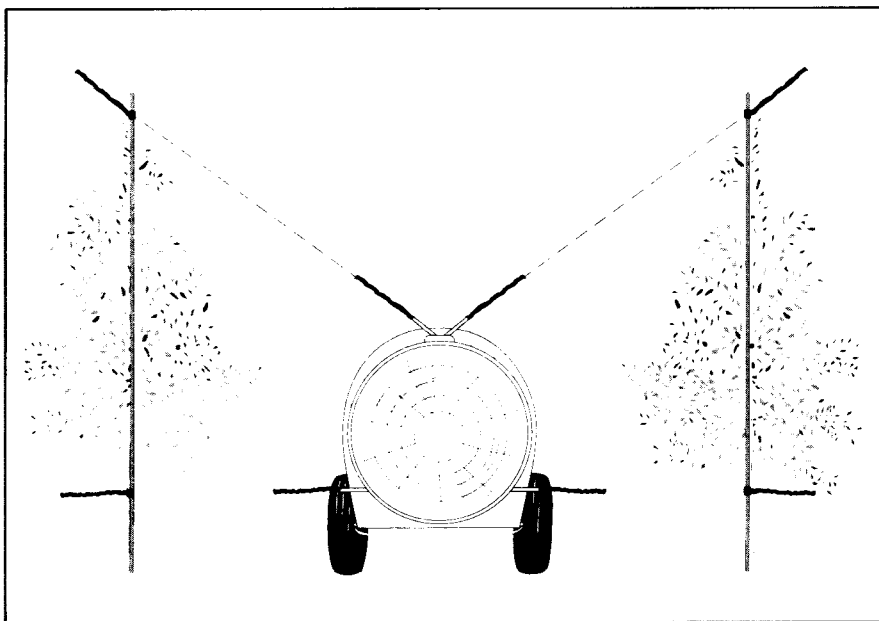

Figure 8. Checking the angle of the air discharge.

## Application Tips

- Always follow label directions with pesticide applications.
- Keep the sprayer running just until the trees at the ends of the rows have been treated.
- Use wear-resistant nozzles.
- Remember that spray controllers or computers ensure accurate sprayer output, but they cannot compensate for changes in droplet size and spray pattern (which result in poor spray coverage) as nozzles wear.
- Avoid spraying when it is too windy.
- Adjust fan speed to keep the spray within the spray row.
- Adjust the sprayer operation for different tree sizes and canopy densities.
- Prune the trees to allow good spray movement to all parts of the trees.
- Always use personal protective clothing and equipment.

## Summary

Following these practices—conducting a precalibration check, calibrating, and checking during spraying—is an important step toward more efficient, responsible, and profitable production.

### Author

Richard C. Derksen,  
Assistant Professor of Agricultural and  
Biological Engineering at Cornell University

### Acknowledgments

The author would like to acknowledge the contributions of the following:  
Deborah Breth (Lake Ontario Fruit Program) reviewed the material in this bulletin.

New York State Integrated Pest Management Program supported the research that resulted in this fact sheet.

This fact sheet is based on the video *Apple Orchard Spraying: Getting Results*, produced in cooperation with DowElanco.

### Disclaimer

Mention or omission of a trade name does not imply endorsement of or lack of confidence in any particular brand of product.

### Copyright

©April 1993 by Northeast Regional  
Agricultural Engineering Service.  
All rights reserved. Inquiries invited.

**Northeast Regional  
Agricultural Engineering Service  
Cooperative Extension  
152 Riley-Robb Hall  
Ithaca, New York 14853-5701  
(607) 255-7654**

**NRAES is an activity of thirteen  
land grant universities and the  
United States Department of Agriculture.  
The following are cooperating members:**

University of Connecticut • University of Delaware  
University of the District of Columbia  
University of Maine • University of Maryland  
Cornell University • University of Massachusetts  
University of New Hampshire • Rutgers University  
The Pennsylvania State University  
University of Rhode Island • University of Vermont  
West Virginia University